



NGN GROUP TUBE

Friendly Service... Powerful Solutions™

HOT DIP GALVANIZED



HOT DIP GALVANIZED

NGN GROUP is proud to support the rebuilding of our nations infrastructure by offering new Hot Dipped Galvanized products that meet the strict requirements for outdoor installation in a harsh environment

Hot Dip Galvanized Products

NGN GROUP Hot Dip Galvanized Electrical Fittings are designed to resist corrosion and provide superior protection from harsh environments

Can be used on infrastructure projects like Bridges, Tunnels, Railways and other large mass transit projects where approved

- UL Listed E195122, E148716, E174011, E195124
- NEMA FB1
- Conforms to finish thickness ASTM A123/123M

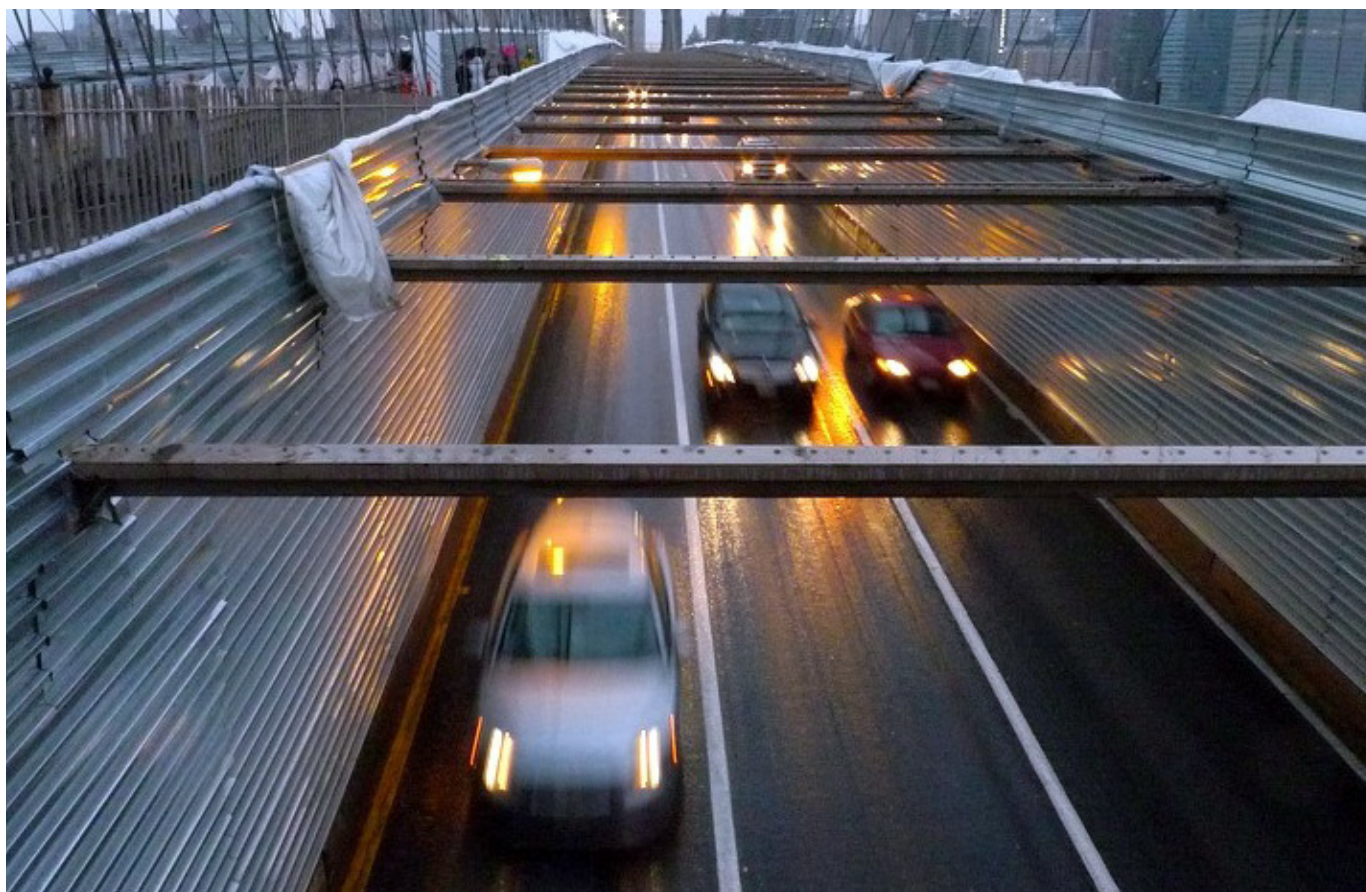

The Hot Dip Galvanized Process

The Hot Dip Galvanized process is achieved by passing the product through a molten bath of zinc at an extreme temperature. This results in a metallurgical bond between zinc and steel with a series of distinct iron-zinc alloys. The hot zinc forms a thicker coating which prevents corrosion to the product and forms a physical barrier, which acts as a sacrificial anode should the barrier be damaged.

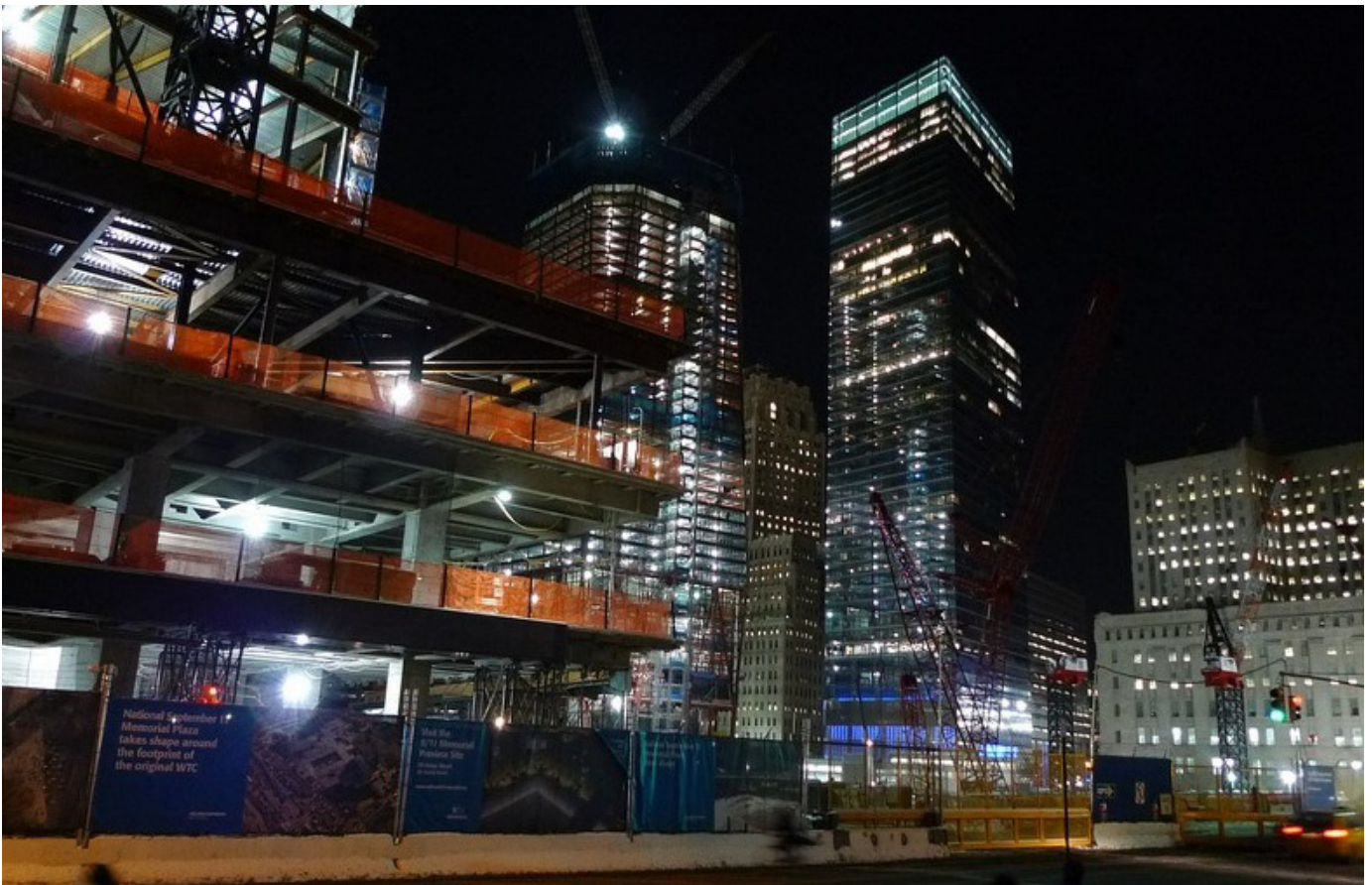
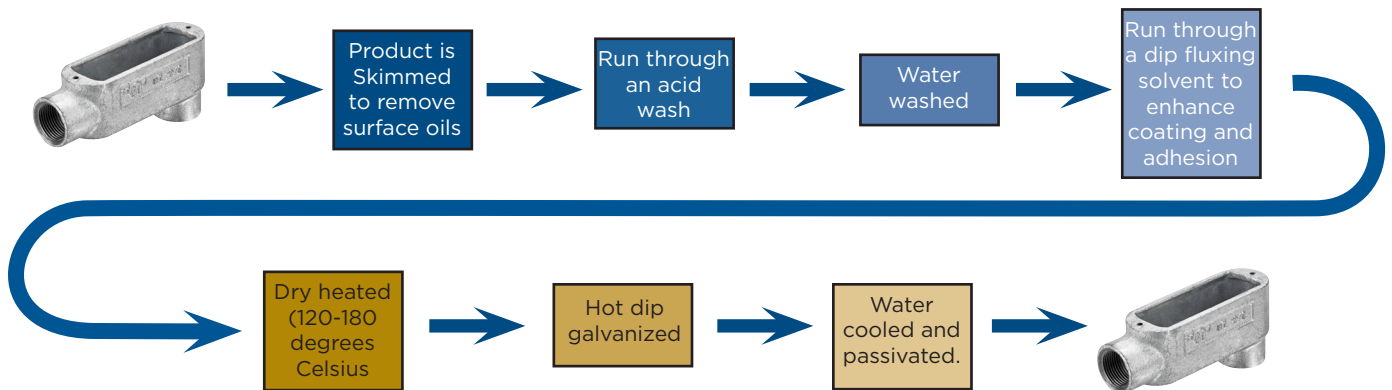

HOT DIP GALVANIZED

RIGID LB TYPE WITH ROLLERS

APPLICATIONS:

- Provide taps for branch conduit runs
- Make 90 degree bends in conduit runs
- Act as pull outlets for conductors being installed
- Provide openings for making splices and taps in conductors
- Provide for access to conductors for maintenance and future system changes
- Connect conduit sections

FEATURES:

- Built-in rollers to facilitate wire pulling.
- Hot Dip Galvanized finish provides superior protection against severe environmental factors.
- Meets project specifications for Department of Transportation & Mass Transit.
- For use on infrastructure projects including bridges, subways, railways and other means of transportation.
- For Governmental Use on Federal and State approved Projects

MATERIAL:

- Body Malleable Iron
- Rollers Steel

FINISH:

Hot Dip Galvanized

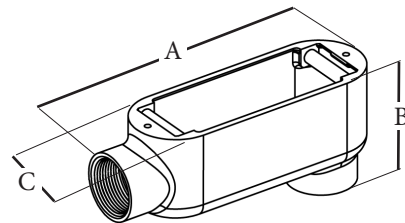

Part No.	UPC	Trade Size	Type	Ship Case	Weight Case	Max No. Conductors	Internal Volume (in ³)	A	B	C
LBR4MHDG	86670	1-1/4"	LBR	5	13	3#2 AWG	32.3	8.12	3.49	2.52
LBR5MHDG	86671	1-1/2"	LBR	2	7	3#1/0 AWG	35.3	8.15	3.69	2.52
LBR6MHDG	86672	2"	LBR	1	6	3#4/0 AWG	73	10.53	4.52	3.15
LBR7MHDG	86673	2-1/2"	LBR	1	11	3-300 MCM	138	13.76	5.39	4.45
LBR8MHDG	86674	3"	LBR	1	13	3-350 MCM	170	13.82	6.18	4.45
LBR9MHDG	86675	3-1/2"	LBR	1	22	3-500 MCM	300	16.65	7.19	5.53
LBR10MHDG	86676	4"	LBR	1	24	3-500 MCM	328	16.65	7.36	5.53

RIGID LB TYPE

APPLICATIONS:

- Provide taps for branch conduit runs
- Make 90 degree bends in conduit runs
- Act as pull outlets for conductors being installed
- Provide openings for making splices and taps in conductors
- Provide for access to conductors for maintenance and future system changes
- Connect conduit sections

FEATURES:

- Hot Dip Galvanized finish provides superior protection against severe environmental factors.
- Meets project specifications for Department of Transportation & Mass Transit.
- For use on infrastructure projects including bridges, subways, railways and other means of transportation.
- For Governmental Use on Federal and State approved Projects

MATERIAL:

- Body Malleable Iron

FINISH:

Hot Dip Galvanized

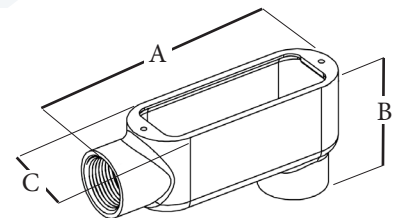

Part No.	UPC	Trade Size	Type	Ship Case	Weight Case	Max No. Conductors	Internal Volume (in ³)	A	B	C
LB1MHDG	86613	1/2"	LB	10	7	---	4.5	4.69	2.18	1.36
LB2MHDG	86614	3/4"	LB	10	9	3#6 AWG	7.5	5.42	2.36	1.57
LB3MHDG	86615	1"	LB	5	6	3#4 AWG	12.5	6.28	2.86	1.79
LB4MHDG	86616	1-1/4"	LB	5	12	3#2 AWG	32.3	8.12	3.49	2.52
LB5MHDG	86617	1-1/2"	LB	2	11	3#1/0 AWG	35.3	8.15	3.69	2.52
LB6MHDG	86618	2"	LB	1	6	3#4/0 AWG	73	10.53	4.52	3.15
LB7MHDG	86619	2-1/2"	LB	1	10	3-300 MCM	138	13.76	5.39	4.45
LB8MHDG	86620	3"	LB	1	13	3-350 MCM	170	13.82	6.18	4.45
LB9MHDG	86621	3-1/2"	LB	1	22	3-500 MCM	300	16.65	7.19	5.53
LB10MHDG	86622	4"	LB	1	24	3-500 MCM	328	16.65	7.36	5.53

HOT DIP GALVANIZED

RIGID C TYPE WITH ROLLERS

APPLICATIONS:

- Provide taps for branch conduit runs
- Make 90 degree bends in conduit runs
- Act as pull outlets for conductors being installed
- Provide openings for making splices and taps in conductors
- Provide for access to conductors for maintenance and future system changes
- Connect conduit sections

FEATURES:

- Built-in rollers to facilitate wire pulling.
- Hot Dip Galvanized finish provides superior protection against severe environmental factors.
- Meets project specifications for Department of Transportation & Mass Transit.
- For use on infrastructure projects including bridges, subways, railways and other means of transportation.
- For Governmental Use on Federal and State approved Projects

MATERIAL:

- Body Malleable Iron
- Rollers Steel

FINISH:

Hot Dip Galvanized

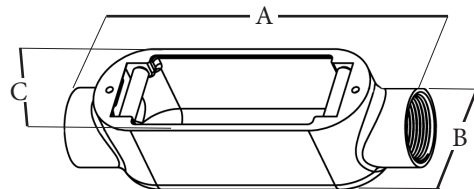

Part No.	UPC	Trade Size	Type	Ship Case	Weight Case	Max No. Conductors	Internal Volume (in ³)	A	B	C
CR4MHDG	86677	1-1/4"	CR	5	15	3#2	32.3	9.00	2.60	2.52
CR5MHDG	86678	1-1/2"	CR	2	6	3#1/0	35.3	9.07	2.80	2.52
CR6MHDG	86679	2"	CR	1	6	3#3/0	73	11.54	3.52	3.15
CR7MHDG	86680	2-1/2"	CR	1	11	3-250MCM	138	15.28	3.98	4.45
CR8MHDG	86681	3"	CR	1	16	3-250MCM	170	15.39	4.65	4.45
CR9MHDG	86682	3-1/2"	CR	1	28	3-350MCM	300	18.30	5.43	5.53
CR10MHDG	86683	4"	CR	1	24	3-350MCM	328	18.30	5.74	5.53

RIGID C TYPE

APPLICATIONS:

- Provide taps for branch conduit runs
- Make 90 degree bends in conduit runs
- Act as pull outlets for conductors being installed
- Provide openings for making splices and taps in conductors
- Provide for access to conductors for maintenance and future system changes
- Connect conduit sections

FEATURES:

- Hot Dip Galvanized finish provides superior protection against severe environmental factors.
- Meets project specifications for Department of Transportation & Mass Transit.
- For use on infrastructure projects including bridges, subways, railways and other means of transportation.
- For Governmental Use on Federal and State approved Projects

MATERIAL:

- Body Malleable Iron

FINISH:

Hot Dip Galvanized

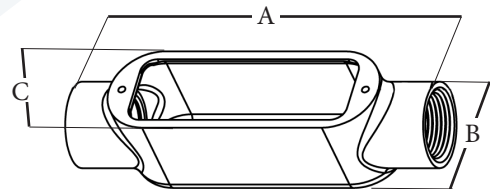
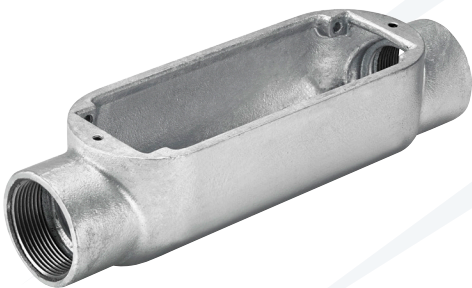

Part No.	UPC	Trade Size	Type	Ship Case	Weight Case	Max No. Conductors	Internal Volume (in ³)	A	B	C
C1MHDG	86643	1/2"	C	10	6	-	4.5	5.43	1.46	1.36
C2MHDG	86644	3/4"	C	10	9	3#6	7.5	6.18	1.65	1.57
C3MHDG	86645	1"	C	5	6	3#4	12.5	7.16	1.98	1.79
C4MHDG	86646	1-1/4"	C	5	12	3#2	32.3	9.00	2.60	2.52
C5MHDG	86647	1-1/2"	C	2	6	3#1/0	35.3	9.07	2.80	2.52
C6MHDG	86648	2"	C	1	6	3#3/0	73	11.54	3.52	3.15
C7MHDG	86649	2-1/2"	C	1	10	3-250MCM	138	15.28	3.98	4.45
C8MHDG	86650	3"	C	1	15	3-250MCM	170	15.39	4.65	4.45
C9MHDG	86651	3-1/2"	C	1	27	3-350MCM	300	18.30	5.43	5.53
C10MHDG	86652	4"	C	1	24	3-350MCM	328	18.30	5.74	5.53

HOT DIP GALVANIZED

RIGID LL TYPE

APPLICATIONS:

- Provide taps for branch conduit runs
- Make 90 degree bends in conduit runs
- Act as pull outlets for conductors being installed
- Provide openings for making splices and taps in conductors
- Provide for access to conductors for maintenance and future system changes
- Connect conduit sections

FEATURES:

- Hot Dip Galvanized finish provides superior protection against severe environmental factors.
- Meets project specifications for Department of Transportation & Mass Transit.
- For use on infrastructure projects including bridges, subways, railways and other means of transportation.
- For Governmental Use on Federal and State approved Projects

MATERIAL:

- Body Malleable Iron

FINISH:

Hot Dip Galvanized

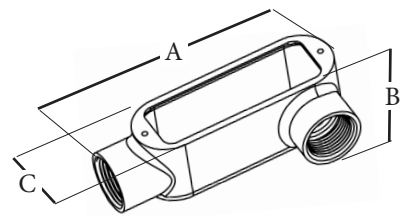

Part No.	UPC	Trade Size	Type	Ship Case	Weight Case	Max No. Conductors	Internal Volume (in ³)	A	B	C
LL1MHDG	86623	1/2"	LL	10	7	-	4.5	4.69	1.46	2.08
LL2MHDG	86624	3/4"	LL	10	10	3#6	7.5	5.42	1.65	2.31
LL3MHDG	86625	1"	LL	5	6	3#4	12.5	6.28	1.98	2.68
LL4MHDG	86626	1-1/4"	LL	5	13	3#2	32.3	8.12	2.60	3.41
LL5MHDG	86627	1-1/2"	LL	2	6	3#1/0	35.3	8.15	2.80	3.45
LL6MHDG	86628	2"	LL	1	6	3#4/0	73	10.53	3.52	4.15
LL7MHDG	86629	2-1/2"	LL	1	10	3-300MCM	138	13.76	3.98	5.86
LL8MHDG	86630	3"	LL	1	13	3-350MCM	170	13.82	4.65	5.92
LL9MHDG	86631	3-1/2"	LL	1	22	3-350MCM	300	16.65	5.43	7.14
LL10MHDG	86632	4"	LL	1	24	3-350MCM	328	16.65	5.74	7.19

RIGID LR TYPE

APPLICATIONS:

- Provide taps for branch conduit runs
- Make 90 degree bends in conduit runs
- Act as pull outlets for conductors being installed
- Provide openings for making splices and taps in conductors
- Provide for access to conductors for maintenance and future system changes
- Connect conduit sections

FEATURES:

- Hot Dip Galvanized finish provides superior protection against severe environmental factors.
- Meets project specifications for Department of Transportation & Mass Transit.
- For use on infrastructure projects including bridges, subways, railways and other means of transportation.
- For Governmental Use on Federal and State approved Projects

MATERIAL:

- Body Malleable Iron

FINISH:

Hot Dip Galvanized

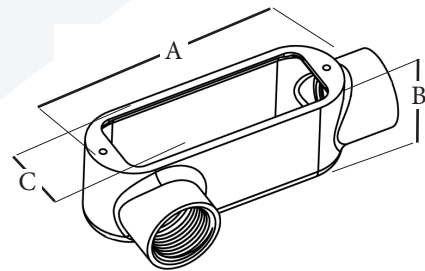

Part No.	UPC	Trade Size	Type	Ship Case	Weight Case	Max No. Conductors	Internal Volume (in ³)	A	B	C
LR1MHDG	86633	1/2"	LR	10	7	-	4.5	4.69	1.46	2.08
LR2MHDG	86634	3/4"	LR	10	10	3#6	7.5	5.42	1.65	2.31
LR3MHDG	86635	1"	LR	5	6	3#4	12.5	6.28	1.98	2.68
LR4MHDG	86636	1-1/4"	LR	5	13	3#2	32.3	8.12	2.60	3.41
LR5MHDG	86637	1-1/2"	LR	2	6	3#1/0	35.3	8.15	2.80	3.45
LR6MHDG	86638	2"	LR	1	6	3#4/0	73	10.53	3.52	4.15
LR7MHDG	86639	2-1/2"	LR	1	10	3-300MCM	138	13.76	3.98	5.86
LR8MHDG	86640	3"	LR	1	13	3-350MCM	170	13.82	4.65	5.92
LR9MHDG	86641	3-1/2"	LR	1	22	3-350MCM	300	16.65	5.43	7.14
LR10MHDG	86642	4"	LR	1	24	3-350MCM	328	16.65	5.74	7.19

HOT DIPPED GALVANIZED

RIGID T TYPE MALLEABLE IRON

APPLICATIONS:

- Provide taps for branch conduit runs
- Make 90 degree bends in conduit runs
- Act as pull outlets for conductors being installed
- Provide openings for making splices and taps in conductors
- Provide for access to conductors for maintenance and future system changes
- Connect conduit sections

FEATURES:

- Hot Dip Galvanized finish provides superior protection against severe environmental factors.
- Meets project specifications for Department of Transportation & Mass Transit.
- For use on infrastructure projects including bridges, subways, railways and other means of transportation.
- For Governmental Use on Federal and State approved Projects

MATERIAL:

- Body Malleable Iron

FINISH:

Hot Dip Galvanized

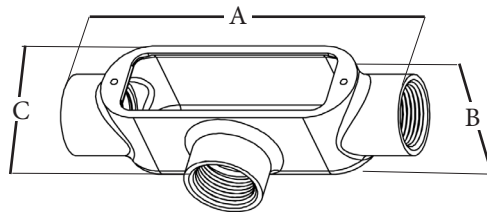
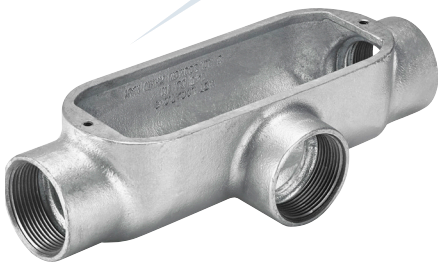

Part No.	UPC	Trade Size	Type	Ship Case	Weight Case	Max No. Conductors	Internal Volume (in ³)	A	B	C
T1MHDG	86653	1/2"	T	10	9	-	6	5.35	1.31	2.02
T2MHDG	86654	3/4"	T	10	11	3#6	9.5	6.00	1.62	2.22
T3MHDG	86655	1"	T	5	8	3#4	15	7.06	1.88	2.56
T4MHDG	86656	1-1/4"	T	5	14	3#2	33	7.25	2.50	3.50
T5MHDG	86657	1-1/2"	T	2	6	3#1	36	9.25	2.67	3.50
T6MHDG	86658	2"	T	1	6	3#2/0	75	11.50	3.29	4.25
T7MHDG	86659	2-1/2"	T	1	12	3#4/0	138	15.00	3.94	5.72
T8MHDG	86660	3"	T	1	15	3#4/0	170	15.125	4.75	8.88
T9MHDG	86661	3-1/2"	T	1	27	3-350MCM	300	18.125	5.20	6.81
T10MHDG	86662	4"	T	1	28	3-350MCM	328	18.125	5.56	7.20

MALLEABLE IRON COVER

APPLICATIONS:

Use to cover malleable iron conduit bodies. 1/2"-4"

FEATURES:

Hot Dip Galvanized for added durability and corrosion protection, use with Gasket for wet locations.

MATERIAL:

- Malleable Iron
- Galvanized Steel Screws

FINISH:

Hot Dip Galvanized

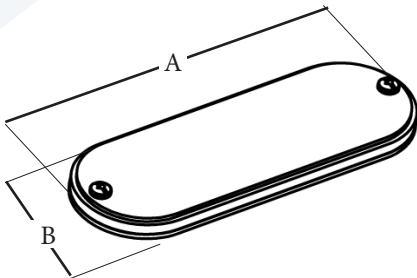
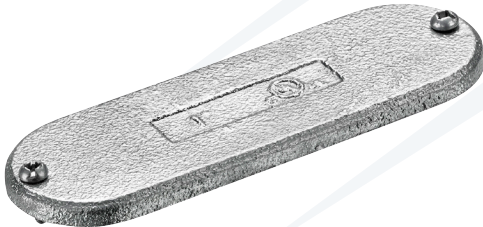

Part No.	UPC	Description	Unit Ctn.	Ship Case	Weight Case	A	B
571MHDG	86663	1/2" Malleable Iron Cover	10	100	24	3.97	1.34
572MHDG	86664	3/4" Malleable Iron Cover	10	100	31	4.68	1.57
573MHDG	86665	1" Malleable Iron Cover	5	50	21	5.39	1.79
574MHDG	86666	1-1/4" & 1-1/2" Malleable Iron Cover	---	25	23	7.23	2.52
576MHDG	86667	2" Malleable Iron Cover	---	25	52	9.51	3.15
577MHDG	86668	2-1/2" & 3" Malleable Iron Cover	---	10	35	12.24	4.45
579MHDG	86669	3-1/2" & 4" Malleable Iron Cover	---	10	55	14.99	5.53

HOT DIP GALVANIZED

RIGID COUPLING

APPLICATIONS:

Used to join two lengths of threaded conduit

FEATURES:

For threaded rigid conduit Hot Dip Galvanized for superior protection against corrosion

MATERIAL:

Iron

FINISH:

Hot Dip Galvanized

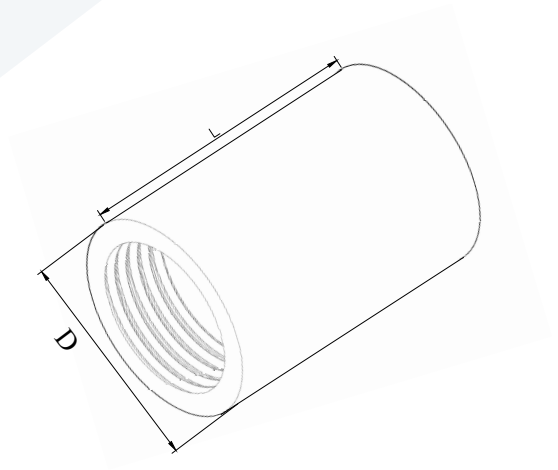

Part No.	UPC	Description	Unit Ctn.	Ship Case	Weight Case	L	D
851HDG	86703	PG 7 Rigid 1-Piece Coupling Iron	20	200	24	20	14
852HDG	86704	PG 9 Rigid 1-Piece Coupling Iron	10	100	30	20	17
853HDG	86705	PG11 Rigid 1-Piece Coupling Iron	5	50	23	25	20
854HDG	86706	PG13.5 Rigid 1-Piece Coupling Iron	5	50	55	29	22
855HDG	86707	PG 16 Rigid 1-Piece Coupling Iron	3	30	44	30	30
856HDG	86708	PG 21 Rigid 1-Piece Coupling Iron	2	20	44	35	30
857HDG	86709	PG 29 Rigid 1-Piece Coupling Iron	---	10	37	41	41
858HDG	86710	PG 36 Rigid 1-Piece Coupling Iron	---	5	20	50	51
859HDG	86711	PG 42 Rigid 1-Piece Coupling Iron	---	5	28	50	58
860HDG	86712	PG 48 Rigid 1-Piece Coupling Iron "	---	2	18	58	64

MALLEABLE INSULATED GROUNDING BUSHINGS

APPLICATIONS:

Used to provide a means of grounding Rigid or IMC conduit.

FEATURES:

Tin Plated aluminum alloy 6060-T6 rated for AL and CU conductor. 150°C plastic insuliner. Hot Dip Galvanized for superior protection against corrosion.

MATERIAL:

Malleable Iron
Aluminum Lug
Plastic Insuliner

FINISH:

Hot Dip Galvanized

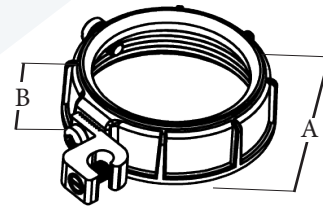

Part No.	UPC	Description	Unit Ctn.	Ship Case	Weight Case	A	B
331MHDG	86684	1/2" Rigid Malleable Insulated Grounding Bushings	50	500	45	1.08	.57
332MHDG	86685	3/4" Rigid Malleable Insulated Grounding Bushing	50	500	50	1.31	.57
333MHDG	86686	1" Rigid Malleable Insulated Grounding Bushing	25	250	32	1.61	.65
334MHDG	86688	1-1/4" Rigid Malleable Insulated Grounding Bushing	20	200	36	1.91	.71
335MHDG	86690	1-1/2" Rigid Malleable Insulated Grounding Bushing	10	100	25	2.16	.73
336MHDG	86692	2" Rigid Malleable Insulated Grounding Bushing	10	100	30	2.72	.73
337MHDG	86693	2-1/2" Rigid Malleable Insulated Grounding Bushing	5	50	25	3.23	.94
338MHDG	86695	3" Rigid Malleable Insulated Grounding Bushing	---	25	18	3.88	.94
339MHDG	86697	3-1/2" Rigid Malleable Insulated Grounding Bushing	---	10	20	4.43	.94
340MHDG	86699	4" Rigid Malleable Insulated Grounding Bushing	---	10	24	4.89	.94
340ALMHDG	86701	5" Rigid Malleable Insulated Grounding Bushing	---	10	27	6.10	1.14
340BLMHDG	86702	6" Rigid Malleable Insulated Grounding Bushing	---	10	32	7.15	1.14

HOT DIP GALVANIZED

EMT/RIGID CLAMP BACKS MALLEABLE IRON

APPLICATIONS:

For use in wet or dry locations in conjunction with malleable rigid conduit straps to create space between conduit and mounting surface.

FEATURES:

Hot Dip Galvanized for added durability and corrosion protection.

MATERIAL:

Malleable Iron

FINISH:

Hot Dip Galvanized

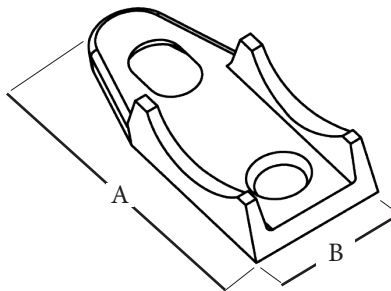

Part No.	UPC	Description	Unit Ctn.	Ship Case	Weight Case	A	B	C
481HDG	86601	1/2" EMT/RGD Clamp Back	25	250	15	2.06	1.01	.44
482HDG	86602	3/4 " EMT/RGD Clamp Back	25	250	23	2.44	1.20	.48
483HDG	86603	1" EMT/RGD Clamp Back	25	250	35	2.92	1.31	.56
484HDG	86604	1-1/4" EMT/RGD Clamp Back	10	100	21	3.41	1.49	.67
485HDG	86605	1-1/2 " EMT/RGD Clamp Back	10	100	27	3.78	1.52	.76
486HDG	86606	2" EMT/RGD Clamp Back	5	50	22	4.73	1.92	.80
487HDG	86607	2-1/2" EMT/RGD Clamp Back	---	25	14	5.48	2.42	.80
488HDG	86608	3" EMT/RGD Clamp Back	---	10	9	6.66	2.63	.83
489HDG	86609	3-1/2" EMT/RGD Clamp Back	---	12	10	7.12	2.87	1.03
489AHDG	86610	4" EMT/RGD Clamp Back	---	18	21	8.43	3.12	1.09
489BHDG	86611	5" EMT/RGD Clamp Back	---	10	21	10.78	3.68	1.30
489CHDG	86612	6" EMT/RGD Clamp Back	---	10	29	12.68	3.96	1.89

1 HOLE RIGID STRAP

APPLICATIONS:

Use to secure Rigid or IMC conduit to wood, masonry or similar surfaces where greater load bearing is required.

FEATURES:

Hot Dip Galvanized for added durability and corrosion protection.

MATERIAL:

Malleable Iron

FINISH:

Hot Dip Galvanized

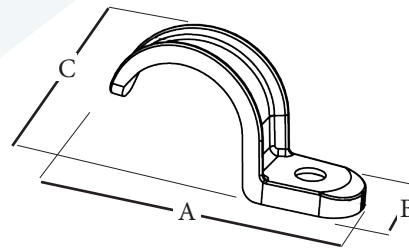

Part No.	UPC	Description	Unit Ctn.	Ship Case	Weight Case	A	B	C
561HDG	86589	1/2" 1 Hole Rigid Strap	100	1000	40	1.98	.67	.97
562HDG	86590	3/4" 1 Hole Rigid Strap	50	500	25	2.37	.76	1.10
563HDG	86591	1" 1 Hole Rigid Strap	25	250	20	2.90	.82	1.44
564HDG	86592	1-1/4" 1 Hole Rigid Strap	20	250	25	3.12	.82	1.77
565HDG	86593	1-1/2" 1 Hole Rigid Strap	10	200	32	3.90	1.05	2.06
566HDG	86594	2" 1 Hole Rigid Strap	---	100	36	4.77	1.36	2.59
567HDG	86595	2-1/2" 1 Hole Rigid Strap	---	25	17	5.45	1.36	3.05
568HDG	86596	3" 1 Hole Rigid Strap	---	25	25	6.74	1.54	3.77
569HDG	86597	3-1/2" 1 Hole Rigid Strap	---	25	38	7.72	1.91	4.24
570HDG	86599	4" 1 Hole Rigid Strap	---	10	23	8.13	2.07	4.98
570AHDG	86599	5" 1 Hole Rigid Strap	---	10	34	10.94	2.55	6.22
570BHDG	86600	6" 1 Hole Rigid Strap	---	10	40	12.71	2.91	7.45

HOT DIP GALVANIZED

RIGID SET SCREW CONNECTORS

APPLICATIONS:

Used to join unthreaded rigid or IMC conduit to box or enclosure

FEATURES:

Concrete-tight when taped. Hot Dip Galvanized for added durability and corrosion protection

MATERIAL:

Malleable Iron
Galvanized Steel Screw

FINISH:

Hot Dip Galvanized

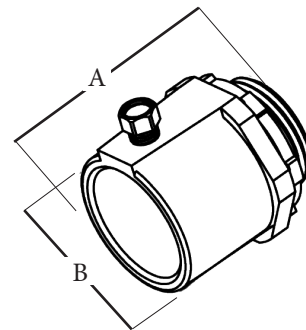

Part No.	UPC	Description	Unit Ctn.	Ship Case	Weight Case	A	B
671MHDG	86725	1/2" Rigid Set Screw Connector Malleable Iron	25	250	24	1.51	1.17
672MHDG	86726	3/4" Rigid Set Screw Connector Malleable Iron	---	25	4	1.75	1.39
673MHDG	86727	1" Rigid Set Screw Connector Malleable Iron	---	25	6	1.98	1.66
674MHDG	86728	1-1/4" Rigid Set Screw Connector Malleable Iron	5	50	22	2.22	2.01
675MHDG	86729	1-1/2" Rigid Set Screw Connector Malleable Iron	5	50	28	2.44	2.25
676MHDG	86730	2" Rigid Set Screw Connector Malleable Iron	---	20	15	2.52	2.75

CABLE GLAND FOR FLAXIBEL CONDUIT

APPLICATIONS:

Used to join two unthreaded lengths of rigid conduit or IMC

FEATURES:

Concrete-tight when taped. Hot Dip Galvanized for added durability and corrosion protection

MATERIAL:

Malleable Iron
Galvanized Steel Screw

FINISH:

Hot Dip Galvanized

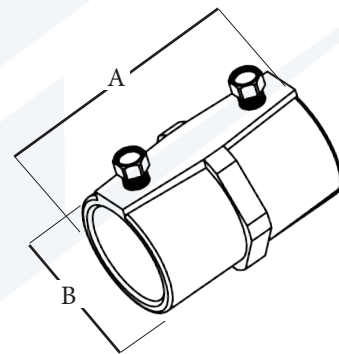

Part No.	UPC	Description	Unit Ctn.	Ship Case	Weight Case	A	B
681MHDG	86731	1/2" Rigid Set Screw Coupling Malleable Iron	---	25	5	1.77	1.17
682MHDG	86732	3/4" Rigid Set Screw Coupling Malleable Iron	---	25	6	1.96	1.39
683MHDG	86733	1" Rigid Set Screw Coupling Malleable Iron	---	25	10	2.69	1.66
684MHDG	86734	1-1/4" Rigid Set Screw Coupling Malleable Iron	5	50	33	2.73	2.01
685MHDG	86735	1-1/2" Rigid Set Screw Coupling Malleable Iron	4	40	29	3.19	2.25
686MHDG	86736	2" Rigid Set Screw Coupling Malleable Iron	---	20	23	3.40	2.75
683MHDG	86733	1" Rigid Set Screw Coupling Malleable Iron	---	25	10	2.69	1.66
684MHDG	86734	1-1/4" Rigid Set Screw Coupling Malleable Iron	5	50	33	2.73	2.01
685MHDG	86735	1-1/2" Rigid Set Screw Coupling Malleable Iron	4	40	29	3.19	2.25
686MHDG	86736	2" Rigid Set Screw Coupling Malleable Iron	---	20	23	3.40	2.75

HOT DIP GALVANIZED

RIGHT ANGLE CONDUIT SUPPORT

APPLICATIONS:

Right-angle conduit clamps are used to mount EMT or rigid conduits across or perpendicular to beam, channel or angle supports

FEATURES:

Hot Dip Galvanized for added durability and corrosion protection. Provides a secure connection and tight clamping action capable of withstanding heavy loads.

MATERIAL:

Malleable Iron
Galvanized Steel Hardware

FINISH:

Hot Dip Galvanized

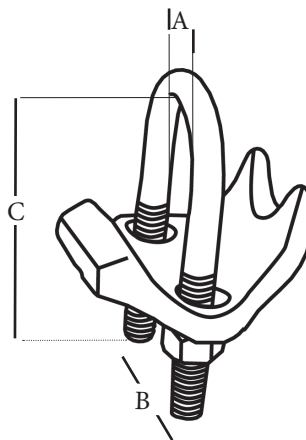
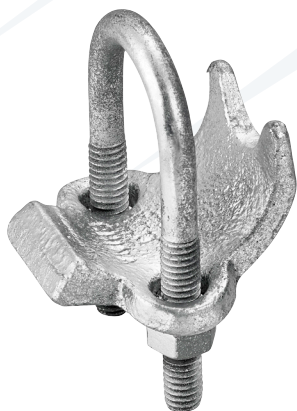

Part No.	UPC	Description	Ship Case	Weight Case	A	B	C
1551HDG	86579	1/2" Right Angle Conduit Support	50	20	.97	1.24	2.46
1552HDG	86580	3/4" Right Angle Conduit Support	50	22	1.15	1.43	2.76
1553HDG	86581	1" Right Angle Conduit Support	50	24	1.42	1.70	3.01
1554HDG	86582	1-1/4" Right Angle Conduit Support	50	27	1.79	2.07	3.16
1555HDG	86583	1-1/2" Right Angle Conduit Support	50	29	2.04	2.32	3.52
1556HDG	86584	2" Right Angle Conduit Support	25	22	2.49	2.83	4.39
1557HDG	86585	2-1/2" Right Angle Conduit Support	25	27	3.06	3.39	4.75
1558HDG	86586	3" Right Angle Conduit Support	25	28	3.65	3.98	5.38
1559HDG	86587	3-1/2" Right Angle Conduit Support	25	32	4.21	4.55	5.76
1559AHDG	86588	4" Right Angle Conduit Support	25	35	4.69	5.03	6.27

PARALLEL CONDUIT SUPPORT

APPLICATIONS:

Parallel conduit supports are used to mount EMT or Rigid Conduits Parallel to a beam, channel or angle supports.

FEATURES:

Hot Dip Galvanized for added durability and corrosion protection. Provides a secure connection and tight clamping action capable of withstanding heavy loads.

MATERIAL:

Malleable Iron
Galvanized Steel Hardware

FINISH:

Hot Dip Galvanized

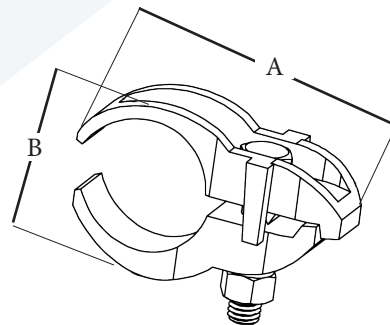

Part No.	UPC	Description	Ship Case	Weight Case	A	B
1561HDG	86737	1/2" Parallel Conduit Support	50	29	2.80	1.42
1562HDG	86738	3/4" Parallel Conduit Support	50	32	2.99	1.47
1563HDG	86739	1" Parallel Conduit Support	50	35	3.19	1.54
1564HDG	86554	1-1/4" Parallel Conduit Support	25	18	3.39	2.01
1565HDG	86555	1-1/2" Parallel Conduit Support	25	24	3.62	2.01
1566HDG	86556	2" Parallel Conduit Support	25	25	4.37	2.87
1567HDG	86557	2-1/2" Parallel Conduit Support	10	14	5.12	3.23
1568HDG	86558	3" Parallel Conduit Support	10	16	5.79	4.06
1569HDG	86559	3-1/2" Parallel Conduit Support	10	19	6.26	4.53
1570HDG	86560	4" Parallel Conduit Support	10	22	6.46	4.61

HOT DIP GALVANIZED

EDGE TYPE CONDUIT SUPPORT

APPLICATIONS:

Edge type conduit supports are used to mount EMT or rigid conduits perpendicular to a beam, channel or angle supports.

FEATURES:

Hot Dip Galvanized for added durability and corrosion protection. Provides a secure connection and tight clamping action capable of withstanding heavy loads.

MATERIAL:

Malleable Iron
Galvanized Steel Hardware

FINISH:

Hot Dip Galvanized

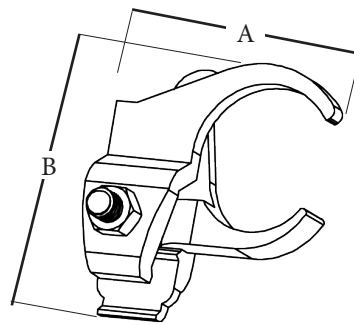
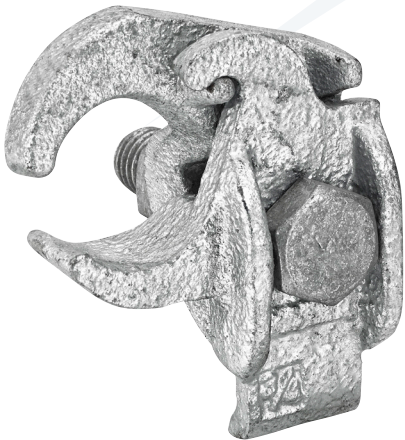

Part No.	UPC	Description	Ship Case	Weight Case	A	B
1571HDG	86561	1/2" Edge Type Conduit Support	50	34	2.10	2.72
1572HDG	86562	3/4" Edge Type Conduit Support	50	36	2.44	3.01
1573HDG	86563	1" Edge Type Conduit Support	50	43	2.57	3.23
1574HDG	86564	1-1/4" Edge Type Conduit Support	25	23	2.96	3.47
1575HDG	86565	1-1/2" Edge Type Conduit Support	25	29	3.27	3.65
1576HDG	86566	2" Edge Type Conduit Support	25	34	3.85	4.36
1577HDG	86567	2-1/2" Edge Type Conduit Support	10	19	4.40	5.05
1578HDG	86568	3" Edge Type Conduit Support	10	23	5.08	5.41

RIGID OFFSET NIPPLES

APPLICATIONS:

Indoor or outdoor use
 Use as an offset connector between two enclosures.
 Offsets the axis of the raceways by 3/4"

FEATURES:

NPSM Thread: Smooth inside surface to facilitate wire pulling free of damage

MATERIAL:

Malleable Iron

FINISH:

Hot Dipped Galvanized

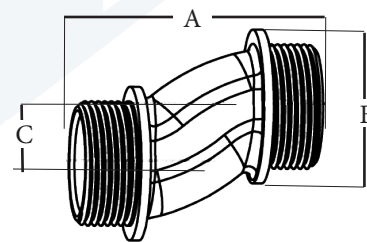

Part No.	UPC	Description	Unit Ctn.	Ship Case	Weight Case	A	B	C
111MHDG	86715	1/2" Rigid Offset Nipple Malleable Iron	10	100	25	2.81	1.02	.75
112MHDG	86716	3/4" Rigid Offset Nipple Malleable Iron	10	100	35	2.75	1.25	.75
113MHDG	86717	1" Rigid Offset Nipple Malleable Iron	10	100	49	2.87	1.56	.75
114MHDG	86718	1-1/4" Rigid Offset Nipple Malleable Iron	5	50	17	3.13	2.00	.75
115MHDG	86719	1-1/2" Rigid Offset Nipple Malleable Iron	5	50	23	3.13	2.31	.75
116MHDG	86720	2" Rigid Offset Nipple Malleable Iron	2	20	13	3.06	2.76	.75
117MHDG	86721	2-1/2" Rigid Offset Nipple Malleable Iron	---	2	6	3.97	3.26	.75
118MHDG	86722	3" Rigid Offset Nipple Malleable Iron	---	2	6	4.43	3.81	.75
119MHDG	86723	3-1/2" Rigid Offset Nipple Malleable Iron	---	1	1	4.82	4.38	.75
119AMHDG	86724	4" Rigid Offset Nipple Malleable Iron	---	1	4	5.04	4.96	.75

HOT DIP GALVANIZED

RMC U-BOLT WITH HEX NUTS

APPLICATIONS:

Used to support EMT/Rigid conduit/IMC

FEATURES:

For EMT/Rigid/IMC. Heavy Duty, Hex nuts included

MATERIAL:

Steel

FINISH:

Mechanically Galvanized

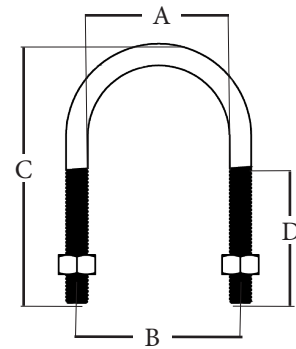
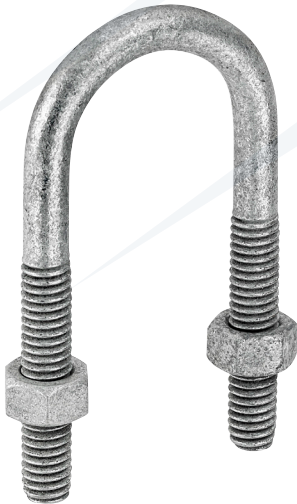

Part No.	UPC	Description	Unit Ctn.	Ship Case	Weight Case	A	B	C	D
761HDG	86569	1/2" RMC U-Bolt with Hex Nuts	25	250	12.5	.97	1.24	2.46	1.50
762HDG	86570	3/4" RMC U-Bolt with Hex Nuts	25	250	15.6	1.15	1.43	2.76	1.50
763HDG	86571	1" RMC U-Bolt with Hex Nuts	25	250	15.7	1.42	1.70	3.01	1.50
764HDG	86572	1-1/4" RMC U-Bolt with Hex Nuts	---	20	15.8	1.79	2.07	3.16	1.50
765HDG	86573	1-1/2" RMC U-Bolt with Hex Nuts	---	20	18.8	2.04	2.32	3.52	1.50
766HDG	86574	2" RMC U-Bolt with Hex Nuts	---	20	31.3	2.49	2.83	4.39	1.96
767HDG	86575	2-1/2" RMC U-Bolt with Hex Nuts	---	20	31.4	3.06	3.39	4.75	1.96
768HDG	86576	3" RMC U-Bolt with Hex Nuts	---	20	37.5	3.65	3.98	5.38	1.96
769HDG	86577	3-1/2" RMC U-Bolt with Hex Nuts	---	20	40.6	4.21	4.55	5.76	1.96
770HDG	86578	4" RMC U-Bolt with Hex Nuts	---	20	43.4	4.69	5.03	6.27	1.96

PLEASE CONTACT YOUR LOCAL SALES REPRESENTATIVE FOR PRICING AND AVAILABILITY

